

SELES
NHB SERİSİ

HASSAS TARTIM TERAZİSİ



ECZACI

Eczane ve kuyumcular için kullanıma uygundur.

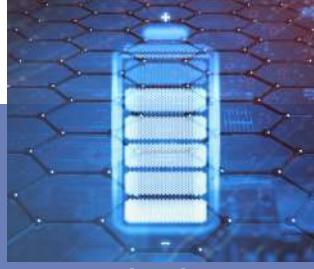

DAHİLİ AKÜ

Dahili akü ile elektrik kesintilerinde tartım işlemine devam edebilirsiniz.



ONAYLI

CE, NTEP, TSE ve BAKANLIK tarafından onaylıdır.

ÖZELLİKLERİ

*Yüksek hassasiyet

KAPASİTE

*600 g kapasite

*0.01 g hassasiyet

İLETİŞİM

NHB SERİSİ HASSAS TERAZİ



TEKNİK ÖZELLİKLERİ

Marka : Seles

Model : Nhb Serisi

Kapasite (kg) : 600 g

Hassasiyet (g) : 0.01 g

Çalışma Sıcaklığı : 5°C ~ +40°C

Ekran : 16.5 mm LCD Ekran

Maks. Bölüntü Değeri : 6000 e

Güç : AC Adaptör(12 V / 500Ma), Şarj Edilebilir Akü (6V/1.2Ah)

Rs-232 : Opsiyonel

Kasa Materyal : Abs Plastik

Platform : Paslanmaz

Platform Ebadı (cm) : Ø 120 mm

Tuş Takımı : 7 adet

Ürün Ölçüleri (mm) : 200 x 255 x 154

Ürün Ağırlığı net / brüt : 2.7 / 2.9 kg - 9 / 9.9 lb

Dara Aralığı : Tam kapasiteye kadar eksiltmeli dara alınabilir.

İLETİŞİM

NHB SERİSİ TEKNİK ÇİZİM

NHB SERİSİ TEKNİK ÇİZİM

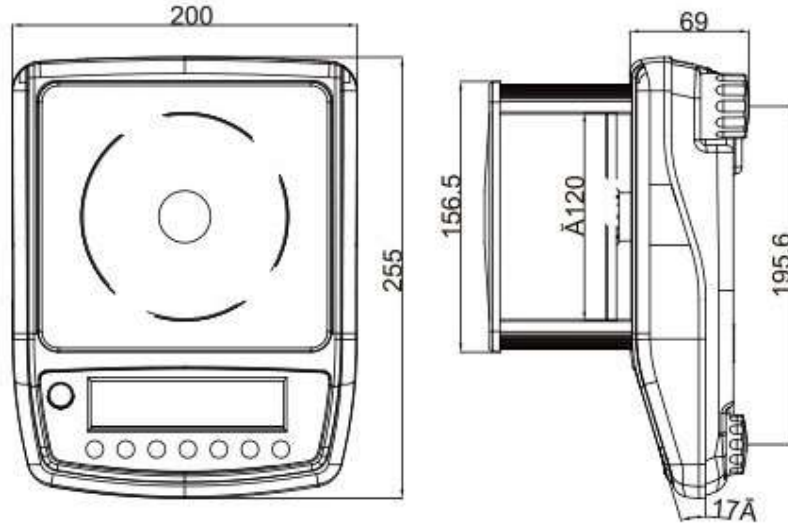

NHB SERİSİ EKRAN

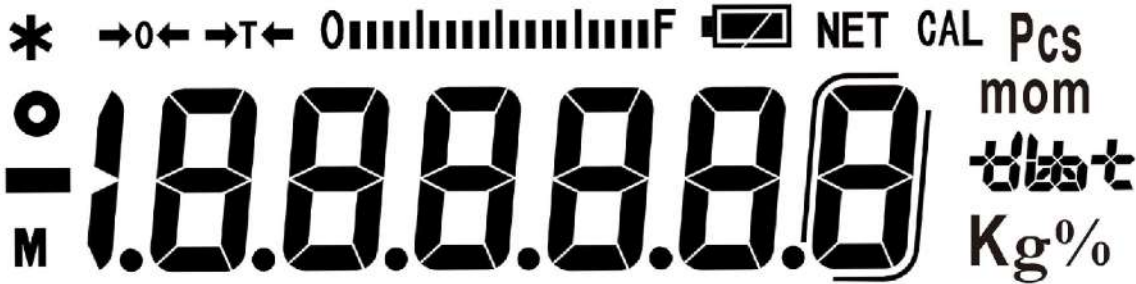

İLETİŞİM